

Downstream Process Synthesis for Biochemical Production of Butanol, Ethanol, and Acetone from Grains: Generation of Optimal and Near-Optimal Flowsheets with Conventional Operating Units

Jiahong Liu and L. T. Fan*

Department of Chemical Engineering, Kansas State University, Manhattan, Kansas 66506

Paul Seib

Department of Grain Science and Industry, Kansas State University, Manhattan, Kansas 66506

Ferenc Friedler and Botond Bertok

Department of Computer Science, University of Veszprem, Veszprem, Egyetem u. 10, H-8200 Hungary

Manufacturing butanol, ethanol, and acetone through grain fermentation has been attracting increasing research interest. In the production of these chemicals from fermentation, the cost of product recovery constitutes the major portion of the total production cost. Developing cost-effective flowsheets for the downstream processing is, therefore, crucial to enhancing the economic viability of this manufacturing method. The present work is concerned with the synthesis of such a process that minimizes the cost of the downstream processing. At the outset, a wide variety of processing equipment and unit operations, i.e., operating units, is selected for possible inclusion in the process. Subsequently, the exactly defined superstructure with minimal complexity, termed maximal structure, is constructed from these operating units with the rigorous and highly efficient graph-theoretic method for process synthesis based on process graphs (P-graphs). Finally, the optimal and near-optimal flowsheets in terms of cost are identified.

Introduction

This paper is concerned with the downstream process synthesis for the biochemical production of butanol, ethanol, and acetone from grains. Process synthesis is one of the most, if not the most, effective means of reducing chemical production cost (1–8). Two major classes of methods for process synthesis are heuristic and algorithmic methods; the former is based on heuristic rules derived from past experiences, and the latter is based on mathematical programming procedures resorting to optimization techniques (Appendix 1, Supporting Information). Inevitably, hybrid methods have also been proposed; such methods adopt both heuristic rules and mathematical programming.

Butanol, ethanol, and acetone are major basic commodity chemicals consumed in bulk in a variety of ways, e.g., as fuels, fuel additives, solvents, or precursors for synthesizing various other organic compounds (9, 10). Manufacturing butanol, ethanol, and acetone by fermenting grains has been gaining escalating interest. The conversion of grains has been significantly enhanced through genetic engineering of enzymes (11–14). Nevertheless, the attainable conversion at present remains extremely low, thereby rendering the products exceptionally dilute in the aqueous effluent streams. Hence, the downstream processing to isolate and purify the products

is exceedingly expensive (15). Naturally, reducing the downstream processing cost is essential to minimize the total production cost (16–18).

Various separation methods proposed in the last two decades can possibly be used for the downstream processing in biochemically manufacturing butanol, ethanol, and acetone. These methods include gas stripping (19–21), distillation (22–25), extraction (19), adsorption (20), and pervaporation (14, 21, 26). Almost all of these methods, or unit operations, are among the major means for bioseparations (16, 18, 27, 28). They manifest themselves as operating units, or blocks, in the flowsheets for downstream processing.

This work aims at generating, i.e., synthesizing, a variety of technically feasible and cost-effective flowsheets for the downstream processing by incorporating exclusively conventional unit operations. Such unit operations include gas stripping, distillation, and extraction (19, 24). It is most likely that the reliability of these conventional unit operations has been maximized and their cost has been minimized in their long commercial existence. According to Keller and Bryan (7), distillation is still a “formidable competitor” as a major separation method even though much research has been thrust on its alternatives. Hence, distillation, especially simple distillation, tends to be the first choice in industry for separating a liquid mixture; other methods, including complex distillation, e.g., azeotropic distillation, come into play only when simple distillation is deemed to be

* To whom correspondence should be addressed. Tel: (785) 532-5584. Fax: (785) 532-7372. Email: fan@cheme.ksu.edu.

technically infeasible or economical infeasible. At the very initial, or macroscopic, phase of flowsheet synthesis, any complex distillation unit, usually containing two or more pieces of processing equipment, can be regarded as a single operating unit, the composition of which gives rise to separate network synthesis (29–32). The data required for such synthesis involving butanol, ethanol, acetone, and water are available (22, 23, 25). Gas stripping is as simple as or even simpler than simple distillation. Extraction can be a viable alternative to azeotropic distillation; properly incorporated into the flowsheet, it may eliminate the need for azeotropic distillation (19).

To date, almost all, if not all, the works toward the downstream process synthesis or flowsheet generation have apparently been performed heuristically (19, 24, 33). The current work is carried out chiefly by resorting to a graph-theoretic algorithmic method for process-network synthesis based on the process-graph, or P-graph (34–43) (Appendix 2, Supporting Information). This algorithmic method appears to be an effective alternative to other approaches in process synthesis. Lately, the efficacy of this method is being acceleratedly recognized (44); in fact, Keller and Bryan (7) state, "... the P-graph may be the fastest computationally, as well as the method most likely to find a truly optimal solution." Some of the effectual implementations of the P-graph-based process synthesis include waste minimization (45), optimization of chemical complex (46), synthesis of mass exchange network (47), structure simplification of dynamic process model (48), and combinatorial analysis for flowsheet synthesis (49).

The present work specifically involves four consecutive phases. The first is to identify, to the maximum extent possible, available designs or operating modes of unit operations including gas stripping, distillation, and extraction that can potentially be adopted for the downstream processing in biochemical production of butanol, ethanol, and acetone. The second is to establish P-graph representations of the operating units comprising such unit operations. The third is to construct algorithmically the maximal structure of the process of concern, incorporating exhaustively all combinatorially feasible flowsheets in the form of networks containing the operating units represented by P-graphs. The maximal structure is the least complex superstructure that is mathematically defined exactly. The fourth is to generate in the ranked order a finite number of optimal and near-optimal flowsheets.

Process Description

Given herein is the brief description of the process for manufacturing butanol, ethanol, and acetone from grains, specifically, corn (19, 24). The process is composed of two main parts, i.e., fermentation and downstream processing, the latter being the primary focus of the current work. Major species involved in the process are butanol (B), ethanol (E), acetone (A), water (W), and the extraction entrainer, i.e., 2-ethyl-1-hexanol (X) (10, 50; also see Appendix 4, Supporting Information).

Fermentation. Corn is steeped, milled, and converted by enzyme to hydrolyzate. A four-stage fermentation is then carried out in the presence of the improved strain of *Clostridium Acetobutylicum* (19, 24; also see Appendix 5, Supporting Information). In the first stage, the cells are grown under controlled conditions; subsequently, the carbohydrates and organic acids are progressively converted to B, E, and A in the second and third stages; in the fourth stage, the residual carbohydrates are consumed to maximize the yields of B, E, and A.

Downstream Processing. The components in the effluent from the fermentation unit are separated and purified in downstream processing (19, 24).

Feed. The feed to the downstream processing system is the fermentation broth. This broth comprises an aqueous phase in which some solids are suspended. The aqueous phase contains B, E, A, acetic acid, and butyric acid at the concentrations of 1.5, 0.6, 0.2, 0.18, and 0.08 wt %, respectively. During the downstream processing, acetic acid and butyric acid will be converted into E and B, respectively; therefore, the former is lumped with the latter accordingly (24).

Processing. The fermentation broth is fed either to the broth distillation still (gas stripper) after it is heated in a regenerative heat exchanger by the stream from the still's bottom or to the extractor directly.

In the broth distillation still (gas stripper), B, A, and 90% of E are stripped to the still's top as the distillate. It consists of 36 wt % B, 14 wt % A, 3 wt % E, and 47 wt % W. The still's bottom stream contains insoluble protein, fiber, cells, and trace chemicals, such as acetic and butyric acids; it is further processed separately through evaporators, centrifuges, and dryers, thereby producing a high quality dry distiller's dried grains (DDG) for sale as an animal feed. The distillate is subjected to a series of processing steps with various combinations of operating units composed of distillation columns of different types.

If the fermentation broth is fed to the extractor instead of the broth distillation still (gas stripper), X, serving as the entrainer, extracts B, E, A, and trace chemicals, such as acetic and butyric acids, into the extract phase. The raffinate phase, containing 99.6 wt % W and suspended solids, is transported to the waste treatment unit. Apparently, no attempt has been made to recover the suspended solids, possibly because of the toxicity of trace amounts of X. The extract phase, containing 98.3 wt % X and the products, i.e., B, E, and A, is subjected to a series of processing steps, with various combinations of operating units composed of the aforementioned unit operations, i.e., gas stripping, distillation, and extraction.

The stream containing the suspended solids is withdrawn at the very outset of the downstream processing. It is diverted directly to the waste treatment system or processed through a simple sequence of operations to produce the DDG. Thus, it does not come into play in the synthesis of the subsequent separation network; naturally, it does not affect the comparative evaluation of the resultant separation flowsheets.

Products. The downstream processing yields B, E, and A as the final products. It is worth noting that although the major product is B, E and A are as valuable or nearly as valuable as B.

Methodology

The foundation of the graph-theoretic approach to flowsheet generation comprises (a) a novel graph representation in terms of process graphs (P-graphs), (b) a set of rigorous axioms portraying the unique structural features of process networks, and (c) a group of algorithms (34–38, 40–43; also see Appendix 2, Supporting Information).

P-Graph Representation. The structure of a process system is represented by the process graph (P-graph), which is a unique bipartite graph capable of capturing the syntactic and semantic contents of process systems. A P-graph comprises two types of vertexes or nodes for representing materials and operating units, the first

symbolized by circles and the second by horizontal bars. Unlike conventional bipartite graphs, or digraphs, P-graphs can uniquely represent various network structures including those involved in separation-network synthesis.

Axioms. A P-graph comprising a set of operating units and the materials concomitant with them represents a combinatorially feasible process network, i.e., flowsheet, leading from the starting raw materials to the final products if it satisfies a set of the five axioms (34–40). Each of the five axioms interprets the definition of an entity involved, material or operating unit, or states a self-evident truth, e.g., conservation of mass in the context of process-network (flowsheet) synthesis. Each axiom by itself may sound innocent and useless in practice; nonetheless, the five axioms collectively function as a filter to eliminate all combinatorially infeasible or invalid networks, i.e., flowsheets that are invariably included in the complete network (Appendix 2, Supporting Information).

Algorithms. The axioms naturally give rise to efficient algorithms necessary for carrying out the synthesis of feasible networks of flowsheets (Appendices 2 and 3, Supporting Information). These algorithms include MSG (maximal structure generation) for generating the maximal structure, which exclusively contains operating units of all combinatorially feasible networks and thus is the superstructure with minimum complexity (34–36), and ABB (accelerated branch-and-bound) for acceleratedly generating by the modified branch-and-bound technique only a modest number of feasible networks (flowsheets), which are optimal or near-optimal, directly from the maximal structure (37, 40). The networks (flowsheets) can be ranked in terms of the objective function, e.g., cost, operability, and/or sustainability.

Implementation

Five steps are involved in applying the aforementioned methodology to the downstream process synthesis in the biochemical production of butanol (B), ethanol (E), and acetone (A); each of the steps is individually described below.

Specification of Materials. Fermentation broth is the raw material (feed stream) to be processed in the downstream. Pure B, E, A, and water (W) are the products (product streams) from the downstream processing. Intermediate materials, or streams, are all other materials except the raw material (feed stream) and products (product streams).

Identification of Operating Units. Naturally, the identification of operating units is an essential step of the flowsheet generation. To generate the optimal and near-optimal flowsheets, it is mandatory that all operating units plausible for performing necessary processing functions be identified to the maximum extent possible. Various types of separation are considered for the main processing functions involved in the downstream processing of interest in this work. It is worth noting that a separation task can often be carried out by one or more separation methods; naturally, care must be exercised not to disregard or neglect any of them.

The operating units required for the downstream processing can be identified either heuristically or theoretically. In the former, an operating unit performing a certain separation task is scaled on the basis of available empirical knowledge, such as systematically compiled databases, correlations of existing performance data, and past experience. In the latter, an operating unit is

designed according to the first principles, such as various laws, theorems, and mechanistic models of conservation, thermodynamics, chemical kinetics, and transport phenomena. Both the heuristic and theoretical approaches are almost always engaged in practice (1, 32, 51, 52).

As rationalized in the opening section, only the operating units comprising conventional unit operations or equipment are taken into account in the present work. These are gas stripping, distillation, and extraction as described separately in the following.

Gas Stripping Unit. Gas stripping can be regarded as one-equilibrium-stage distillation (52). It effectively serves as a means of roughly removing, at the early stage of downstream processing, a component or components that constitute the major fraction of a material system if these components' volatilities are substantially different from those of the remaining components. This tends to lead to appreciable cost saving (1, 32, 44).

Water (W) and the suspended solids collectively constitute 98 wt % of the fermentation broth. Moreover, their volatilities are appreciably less than those of (EW) and (WB) azeotropes, and A (Appendix 4, Supporting Information). Hence, it is logical to remove W and the suspended solids from the fermentation by gas stripping at the outset of the downstream processing. The gas-stripping unit performing this function is designated as Gas Stripper G1; it comprises one gas stripper. The suspended solids and the sizable fraction of W are withdrawn from the bottom of G1 for further processing to produce byproduct distiller's dried grains (DDG). The desired products, B, E, and A, are stripped and withdrawn in the upper stream. This stream contains 36 wt % of B, 3 wt % of E, 14 wt % of A, and 47 wt % of W. Among these components, the combination of E and W and that of W and B form azeotropes, whereas the others do not (10, 22, 23, 25; also see Appendix 6, Supporting Information). Thus, the complete separation of all of the components requires azeotropic distillation as well as simple distillation if distillation is to be solely adopted in the processing further downstream; each azeotrope behaves as if it is a single component in a simple distillation. In general, azeotropes can give rise to distillation boundaries that make certain separations impossible by simple distillation or prohibitively costly.

Extracting Unit. As an alternative to the gas-stripping unit, an extracting unit can be adopted at the outset of downstream processing to remove W and the suspended solids from the fermentation broth; this unit comprises one extractor and is designated as Extractor E1. With 2-ethyl-1-hexanol (X) as the entrainer, this unit removes the major fraction of the desired products, B, E, and A, from the fermentation broth into the extract phase, thereby leaving the raffinate phase containing 99.6 wt % of W, suspended solids, and small quantities of B, E, and A (Appendix 7, Supporting Information). The raffinate phase is diverted to waste treatment as mentioned earlier. Moreover, no combination of the components in the extract phase, B, E, A, and X, forms any azeotrope (44). Thus, simple distillation suffices for the separation of these components.

Distilling Units. In the descending order of their volatilities, the components in the streams from Gas Stripper G1 or Extractor E1, including the two azeotropes, from the former, to be separated by the downstream processing are: A, (EW), E, (WB), W, B, and X (10; also see Appendices 4 and 6, Supporting Information). The components in this sequence can possibly or plausibly be separated by simple distillation, realized by various simple and/or complex column configurations,

Table 1. Summary of Operating Units Identified and Their Costs

operating units			cost			
no.	no. subunit	designation of equipment	capital (10 ³ US\$)	annualized capital ^a (10 ³ US\$/ year)	operating (10 ³ US\$/ year)	total (10 ³ US\$/ year)
1		H1				
2		F1				
3		G1	2 180	727	871	1 598
4		D1	2 088	696	873	1 569
5		A1	49 653	16 551	218 800	235 351
6		D2	2 294	765	891	1 656
7		D3	1 831	610	864	1 474
8		A2	19 861	6 620	87 520	94 140
9		E1	1 189	396	5 231	5 627
10		S1	1 914	638	864	1 502
11	11-1	D5	2 392	797	902	1 699
	11-2	D6	2 058	686	873	1 559
12	12-1	D7	1 684	561	852	1 413
	12-2	D8	2 275	758	892	1 650
13	13-1, 13-2	D9, D10	6 684	2 228	2 666	4 894
14	14-1, 14-2	D11, D12	6 301	2 100	2 513	4 613
15		D13	6 079	2 026	2 425	4 451
16		D14	6 412	2 137	2 558	4 695
17	17-1, 17-2	D15, D16	6 862	2 287	2 737	5 024
18	18-1, 18-2	D17, D18	6 746	2 249	2 691	4 940
19	19-1, 19-2	D19, D20	8 068	2 689	3 218	5 907
20	20-1, 20-2	D21, D22	3 124	1 041	1 246	2 287
21	21-1, 21-2	D25, D26	4 210	1 403	1 679	3 082
22	22-1, 22-2, 22-3	D27, D28, D29	4 156	1 385	1 658	3 043

^a Based on the 3-year payback period.

into any two or three subsequences of components at the adjacent components whose volatilities differ sufficiently. Moreover, the azeotropes in the sequence, (EW), E, (WB), W, and B, can be separated as described below.

Two binary azeotropes, homogeneous (EW) and heterogeneous (WB), are formed in a mixture containing B, E, A, and W (10, 22, 23, 25). Additional information besides the volatilities of the components involved, e.g., residual curve map (RCM), is necessary to identify a feasible distillation system for separating any azeotrope (1, 32). Azeotropic Distillation Unit A1 is for separating sequence (EW)E(WB)WB into pure E, W, and B. Azeotropic Distillation Unit A2 is for separating sequence (WB)WB into pure W and B.

Table 1 summarizes the plausible operating units identified; they total 22, which are numbered according to the order listed. They comprise 33 pieces of processing equipment (Appendix 8, Supporting Information). Hydrolysis and fermentation do not come into play in the synthesis of the separation network for the downstream processing. Nevertheless, the operating units for hydrolysis reaction and fermentation, identified as Hydrolysis Reactor H1 and Fermenter F1, respectively, are included in the same table for convenience. The calculations for the costs of the operating units are detailed in the subsection Cost Estimation. The resultant costs are summarized in Table 1 for convenience.

P-Graph Representations of Operating Units. All operating units are Graphically represented in conventional diagrams as well as by P-graphs. Figure 1 illustrates such conventional diagrams and P-graphs for two typical operating units (Appendix 9, Supporting Information). The P-graph representations of the operating units are the essential prerequisite to executing algorithms MSG and ABB.

Generation of Comprehensive Flowsheet. On the basis of the specifications of materials and the P-graph representations of the 20 operating units identified, algorithm MSG has constructed the comprehensive flowsheet corresponding to the maximal structure. The total

computing time consumed is less than a second on a 900 MHz Celeron PC.

The comprehensive flowsheet corresponding to the maximal structure is presented in Figures 2 and 3 by conventional and P-graph representations, respectively. It includes all plausible conventional separating units; among them are the units comprising 1 gas stripper, 1 extractor, 27 simple distillation columns, and 2 azeotropic distillation units.

Generation of Optimal and Near-Optimal Flowsheets. The optimal and near-optimal flowsheets can be identified from the comprehensive flowsheet, i.e., the maximal structure, by resorting to algorithm ABB (37, 40; also see Appendix 3, Supporting Information).

Objective Function. In this work, the cost of a flowsheet is defined as the objective function to be minimized. It is calculated as the total sum of the annualized capital costs and operating costs in terms of their present values for all operating units in the flowsheet.

The costs for integrating the operating units and subunits in all flowsheets through piping networks and auxiliary facilities, e.g., pumps, can be neglected at the process-network synthesis or conceptualization stage of process design (1). These costs should be relatively modest compared to those of capital facilities, e.g., distillation columns. Moreover, they would be comparable among the alternative flowsheets for any given process.

The capital cost of an operating unit or subunit is the investment required for purchasing and installing such a unit or subunit. The payback period is set to 3 years in this work. The operating cost of a unit or subunit includes the yearly payment of operating expenses, such as the compensations for labors and management personnel, and expenses for purchasing raw materials and utilities. The compensations for labors and expenses for purchasing raw materials associated with the alternative flowsheets for the process under consideration can be deemed

(a) Operating unit 4

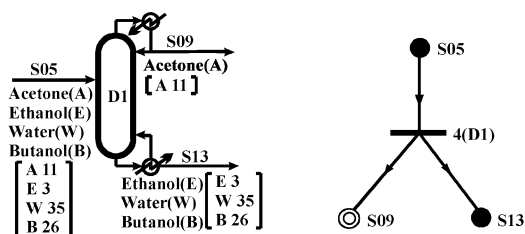

(b) Operating unit 13

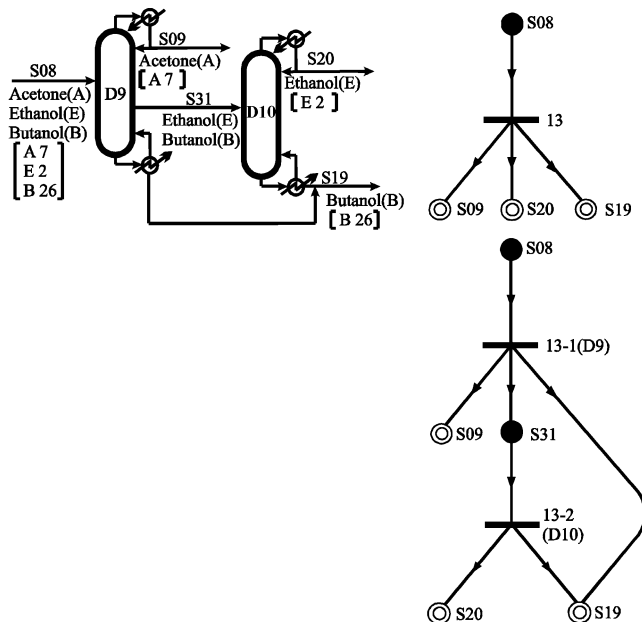

Figure 1. Conventional and P-graph representations of operating units: (a) operating unit 4, consisting of distillation column D1, with the conventional representation on the left and the P-graph representation on the right; (b) operating unit 13, consisting of distillation columns D9 and D10, with the conventional representation on the left, the P-graph representation at the macroscopic level on the upper right, and the P-graph representation at the mesoscopic level on the lower right.

identical except that there is an additional expense for purchasing the entrainer whenever the extractor is included.

Cost Estimation. The design, or synthesis, of any engineered system including a process system is usually carried out in stages, proceeding from the least detail to the most detail with concomitant cost estimates varying from the least precise to the most precise. The approximations made have been described earlier. The process-network synthesis is the first stage of design where the conceptual design is performed rapidly by screening the largest possible number of process alternatives (1, 32, 44).

The cost estimation has been carried out on the basis of the mass and heat balance to produce 200 MM pounds of butanol (B) per year spanning 325 operating days and by specifying the purities of B, E, and A as 99.9 wt %, 99.5 wt %, and 99 wt %, respectively (19). The present value of an operating unit or subunit's cost has been estimated by two methods based on simulation and heuristics. The selection between the two depends on the availability of the cost data and/or the nature of these data for such an operating unit or subunit as elaborated in the following. Whenever sufficient cost data are unavailable, the first method based on simulation is adopted; it resorts to a simulator (e.g., Aspen Plus, Pro/

II, and SuperPro Designer) and a cost estimator (e.g., Aspen Icarus). Otherwise, the second method based on heuristics is employed.

The operating units or subunits whose present values of costs including capital and operating costs have been estimated by the first method include operating units 3 (G1); 4 (D1); 6 (D2); 7 (D3); 10 (S1); 11, comprising subunits 11-1 (D5) and 11-2 (D6); and 12, comprising subunits 12-1 (D7) and 12-2 (D8). Note that all of these units or subunits are distillation columns. In simulating any of the units or subunits with Aspen Plus 11.1, the input data are the feed stream in terms of the feed rate, composition, temperature, and pressure; the compositions of the light and heavy key components in the distillate stream; and the estimated initial reflux ratio or the theoretic number of trays. This unit or subunit is first simulated by Aspen Plus 11.1 to determine the mass and heat balances, as well as other design parameters; the minimum number of theoretic trays and the minimum reflux ratio are computed by varying the estimated initial reflux ratio or the theoretic number of trays. This renders it possible to estimate the energy consumption in the unit of KJ/h and the equipment size in terms of the number of trays. The resultant data are loaded and mapped into Aspen Icarus Process Evaluator 11.1 (50) to evaluate the operating cost and the appropriately amortized capital cost (Appendix 10, Supporting Information); the 3-year payback period is adopted here. The sum of these two costs is the cost of the unit or subunit, which is minimized by iteratively repeating the aforementioned sizing and cost estimating procedures and trading off between the two costs.

The operating units or subunits whose present values of costs including capital and operating costs have been estimated by the second method based on heuristics include two groups of operating units. They are (a) units 8 (A2), 5 (A1), and 9 (E1) and (b) units 13, comprising subunits 13-1 (D9) and 13-2 (D10); 14, comprising subunits 14-1 (D11) and 14-2 (D12); 15 (D13); 16 (D14); 17, comprising subunits 17-1 (D15) and 17-2 (D16); 18, comprising subunits 18-1 (D17) and 18-2 (D18); 19, comprising subunits 19-1 (D19) and 19-2 (D20); 20, comprising subunits 20-1 (D21) and 20-2 (D22); 21, comprising subunits 21-1 (D25) and 21-2 (D26); and 22, comprising subunits 22-1 (D27), 22-2 (D28), and 22-3 (D29).

The three operating units in group (a) have all been in operation or designed. Nevertheless, none of the types of data for cost estimates available for these units are totally identical; they differ in some aspects. Thus, the present values of their costs must be individually estimated somewhat differently (Appendices 11 and 12, Supporting Information).

The data available for estimating the present values of the costs of units or subunits in group (b) are the cost-scaling factors based on the present value of a "reference" unit or subunit's cost or that generated by updating the past value on the basis of the annual rate of inflation. The present value of a unit or subunit's cost is obtained by multiplying the present value of the "reference" unit or subunit's cost with the cost-scaling factor. The "reference" unit for any of the units has been identified as the simple-direct configuration of distillation columns, i.e., unit 11 including subunit 11-1 (D5) and subunit 11-2 (D6) in this work (Table 7.3 of ref 32). On the basis of this "reference" unit, the costs for the units in group (b) are estimated (Appendix 11, Supporting Information).

The cost data and their sources for the operating units

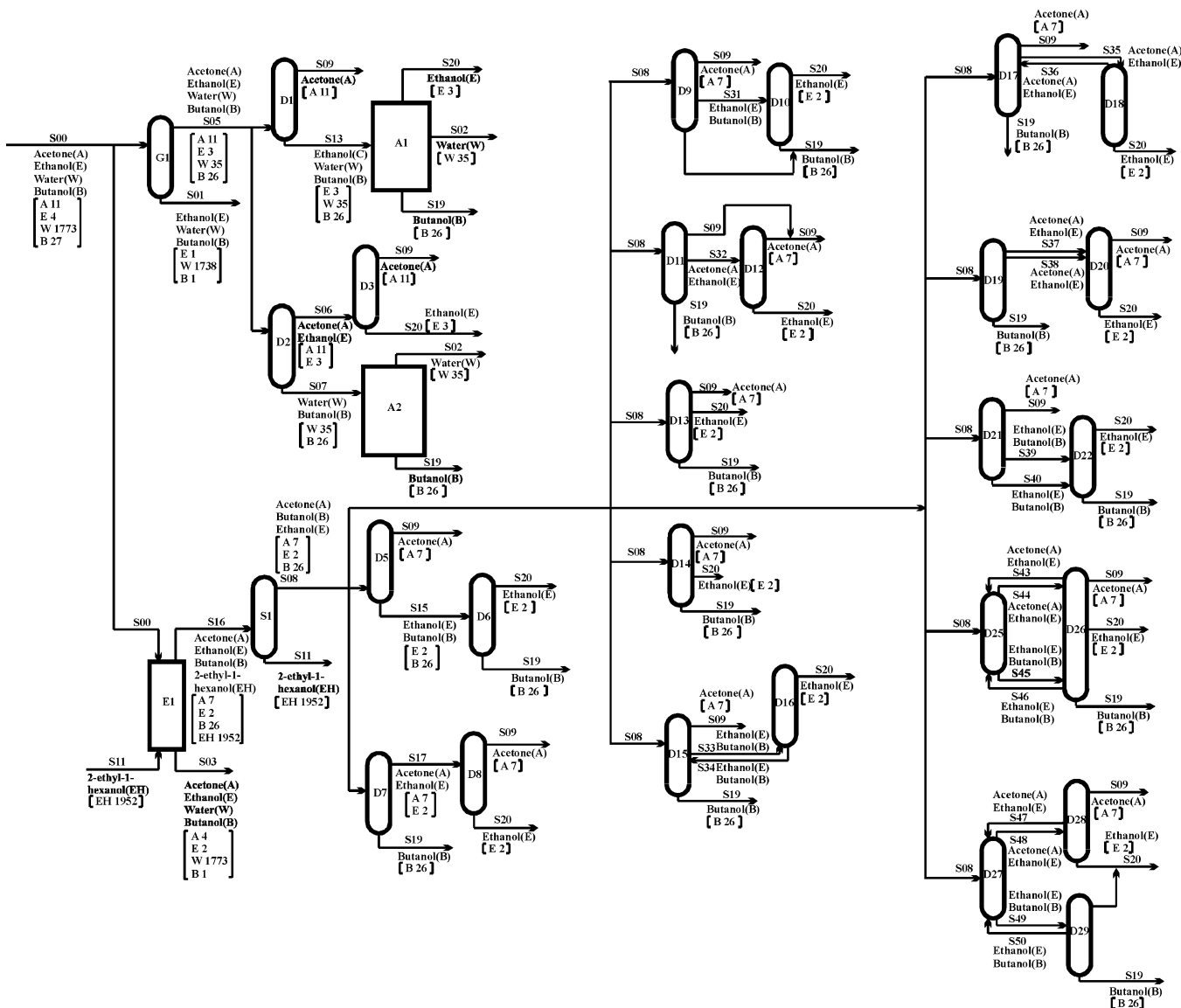

Figure 2. Comprehensive flowsheet corresponding to the maximal structure for the production of butanol, ethanol, and acetone: conventional representation.

and subunits identified are summarized in the above-mentioned Table 1 (Appendix 8, Supporting Information).

Optimal and Near-Optimal Flowsheets. The 10 best flowsheets generated ranking the first through 10th can be discerned in Table 2 (see Appendix 3 in Supporting Information for illustration of the procedure to implement algorithm ABB). The total computing time consumed in generating these 10 best flowsheets is less than 5 s on the same PC used in executing algorithm MSG.

In implementing the branch-and-bound procedure according to algorithm ABB, a list of a finite number of the optimal and near-optimal flowsheets, which is 10 in this work as mentioned above, is updated each time the branching takes place. If the total cost of any branch is larger than that of the 10th best flowsheet already determined to that point, it will not branch further (Appendix 3, Supporting Information). The resultant optimal flowsheet is shown in Figure 4.

Discussion

What follows highlights the noteworthy aspects of the methodology adopted and its implementation. Moreover, significant results obtained are elaborated.

Efficacy of Methodology. Several attributes of the methodology adopted contribute to its profound efficacy. The most prominent are the following. First, the methodology is capable of generating simultaneously a multitude of the optimal and near-optimal flowsheets in the ranked order (37, 40). Apparently, this attribute is absent in any other process-network synthesis methodology proposed to date. Second, the superstructure necessary for the algorithmic synthesis of the flowsheet of interest is rigorously constructed by resorting to a graph-theoretic, polynomial algorithm (34). The resultant superstructure, termed the maximal structure, exclusively contains operating units of all combinatorially feasible networks.

The current methodology can achieve an enormous total reduction in the search space for feasible networks, or flowsheets. For example, only 3465 flowsheets are combinatorially feasible among 3.4×10^9 possible flowsheets from the 35 operating units of a real industrial process (38); this number is merely 0.0001% of the total number of possible networks. This implies that identifying all feasible flowsheets among the possible networks is as difficult as finding a needle in a haystack. Eliminat-

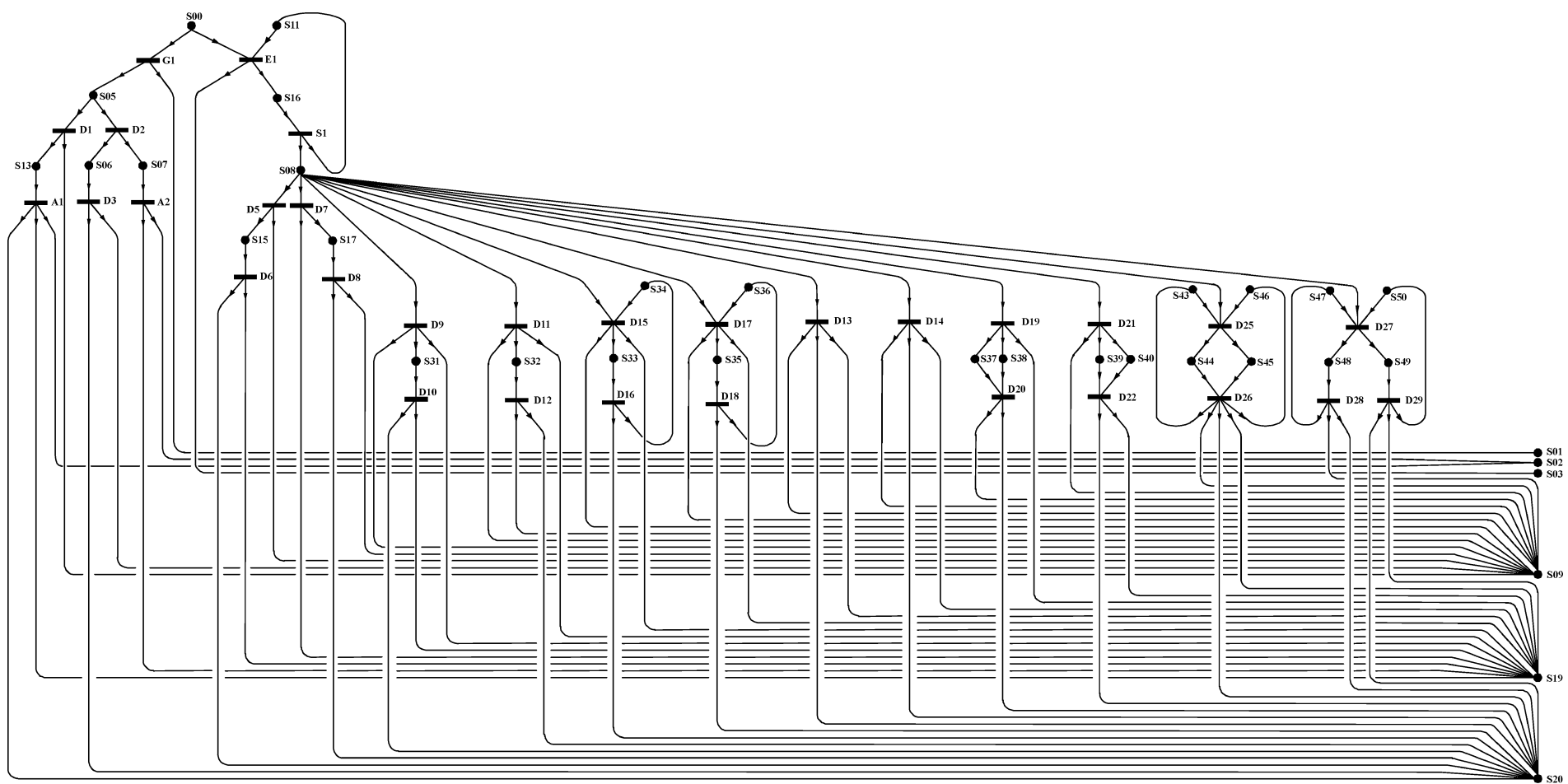

Figure 3. Comprehensive flowsheet corresponding to the maximal structure for the production of butanol, ethanol, and acetone: P-graph representation.

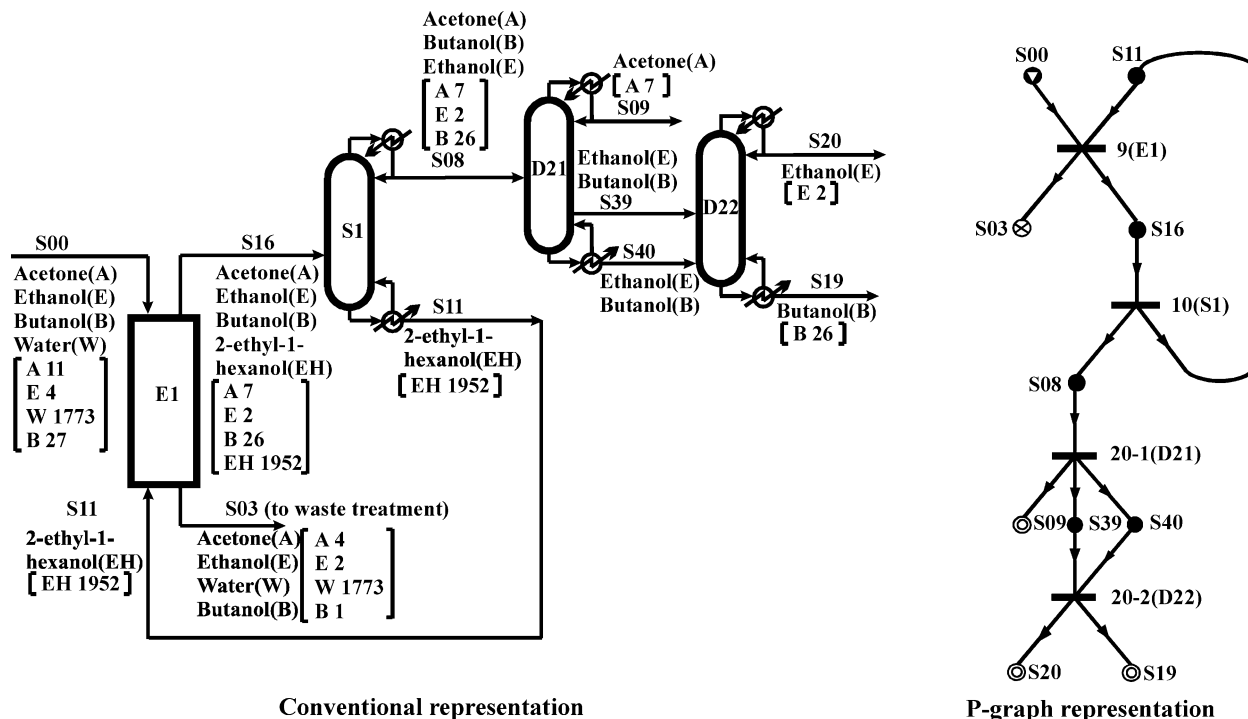

Figure 4. Optimal flowsheet.

Table 2. Optimal and Near-Optimal Flowsheets Generated by Algorithm ABB

rank of the flowsheet	designation of the operating units or subunits included in the flowsheet (the annual cost of the operating units or subunits)	total annual cost of the flowsheet
1	E1 (5627), S1 (1502), D21-D22 (2287)	9 416
2	E1 (5627), S1 (1502), D27-D28-D29 (3043)	10 172
3	E1 (5627), S1 (1502), D7 (1413), D8 (1650)	10 192
4	E1 (5627), S1 (1502), D25-D26 (3082)	10 211
5	E1 (5627), S1 (1502), D5 (1699), D6 (1559)	10 387
6	E1 (5627), S1 (1502), D13 (4451)	11 580
7	E1 (5627), S1 (1502), D11-D12 (4613)	11 742
8	E1 (5627), S1 (1502), D14 (4695)	11 824
9	E1 (5627), S1 (1502), D9-D10 (4894)	12 023
10	E1 (5627), S1 (1502), D17-D18 (4940)	12 069

ing the majority, e.g., 99%, of infeasible or redundant networks to accelerate the search by an order of magnitude can hardly be achieved by any conventional mixed integer programming (MIP) method.

Evaluation of Flowsheets. Table 2 lists the 10 best flowsheets generated in the ranked order on the basis of their total costs. It reveals that generally the incorporation of Extractor E1 eliminates the need for Gas Stripper G1 and Azeotropic Distillation Units A1 and A2 in composing the optimal or near-optimal flowsheets (19). Neither A1 nor A2 is included in any of the 10 best flowsheets.

The 10 best flowsheets are also compared graphically in Figure 5. The optimal flowsheet is noticeably less costly than the four flowsheets ranking the second through fifth, which, in turn, are substantially less expensive than the five ranking the sixth through 10th. It is also revealed in Table 2 that the differences in the costs among the 10 best flowsheets can be attributed to the differences in the configurations of distillation columns in these flowsheets further downstream beyond Extractor E1 and Solvent Stripper S1.

The optimal flowsheet consists of Extractor E1, Solvent Stripper S1, and Distillation Columns D21 and D22. The configuration of these two distillation columns for separating butanol, ethanol, and acetone from each other is referred to as complex-direct (32). The total cost of the

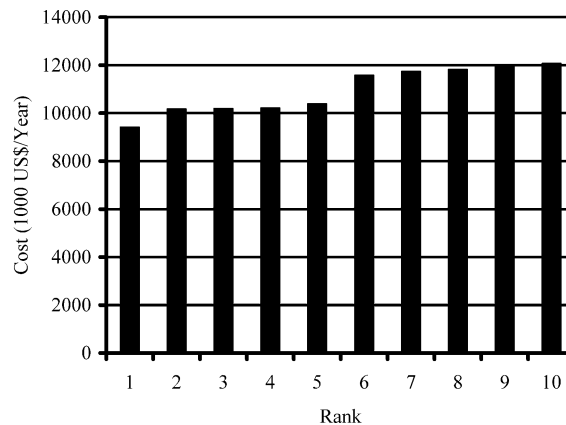

Figure 5. Comparison of the total costs of the 10 best flowsheets.

optimal flowsheet, including the annualized capital and operating costs in terms of their present values, is US\$9,416 × 10³, which is US\$971 × 10³ (10%) and US\$88,557 × 10³ (90%) lower than the fifth and 13th best flowsheets, respectively, both of which are available (19, 24). The total cost of the optimal flowsheet is US\$756 × 10³ (7%) and US\$776 × 10³ (8%) less than the second and third best flowsheets, respectively. The configurations of the two distillation columns in the second and third best flowsheets are referred to as complex-Petlyuk

type IIIb and simple-indirect, respectively (32). Naturally, the cost of the former is lower than that of the latter; moreover, both costs are higher than that of the complex-direct configuration of distillation columns in the optimal flowsheet. It is worth noting that the third best flowsheet closely resembles the fifth best, developed by Dadgar and Foutch (19), as indicated in Table 2. It is also worth noting that the latter flowsheet developed some years ago is one of the near-optimal flowsheets. This clearly indicates the importance of heuristics in the synthesis and design of any complex processes, particularly when only mature technologies, such as distillation and extraction, are involved. It is highly unlikely that the process-synthesis methods as currently known were available at the time these flowsheets were developed.

Assessment of Flowsheets. The flowsheets generated can be assessed in the light of other criteria such as controllability, operability, safety, and sustainability in addition to cost (1, 46). The cost is indeed an appropriate criterion for initially screening the flowsheets to eliminate those that are obviously unprofitable. Nevertheless, the flowsheets surviving the initial screening should be further assessed on the basis of the other criteria. In fact, the current approach is amenable to the incorporation of such criteria. Upon quantification, any of these criteria, including sustainability, can be added to the cost for performing multiobject optimization.

Retrofitting. Under certain circumstances, retrofitting of an existing process can be economically far more viable than constructing a new process, especially when the financial resources are limited and/or when short-term needs are to be met under a tight time constraint. For instance, as indicated in Table 2, suppose that a plant depicted by the fifth best flowsheet is in existence; it can probably be retrofitted to that depicted by the third best flowsheet with relatively modest effort, time, and expenditure because of their close resemblance. This retrofitting can be accomplished by merely replacing distillation columns D5 and D6 with columns D7 and D8, respectively, and carrying out concomitant repiping. The expenditure of the retrofitting includes the costs for D7 and D8 and for repiping. If the last item is neglected, it amounts to $\text{US\$}3,063 \times 10^3$, which is about 33% of the cost for the plant based on the optimal flowsheet. Moreover, if it is feasible to revamp unit 11 comprising D5 and D6 into unit 12 comprising D7 and D8, the cost for the retrofitting can possibly be reduced further. In fact, it might not be out of the question to retrofit the plant based on the fifth best flowsheet to that based on the optimal flowsheet by replacing unit 11 (D5 and D6) with unit 20 (D21 and D22). Obviously, the decision as to the retrofitting or constructing anew is greatly facilitated by the present methodology capable of rapidly and simultaneously generating the optimal and near-optimal flowsheets.

Conclusions

A systematic methodology has been applied to the downstream process synthesis for the biochemical production of butanol, ethanol, and acetone via an efficient algorithmic approach. Optimal and near-optimal flowsheets have been generated in ranked order expeditiously and systematically by the graph-theoretic algorithmic method based on process graphs (P-graphs) and reasonably accurate cost estimate. Such flowsheets are generated from a set of plausible technically mature conventional operating units, each performing a certain processing task. The current work might represent the first successful attempt to algorithmically synthesize the

globally optimal flowsheet for the downstream processing of the biochemical production of chemicals and biochemicals. The methodology adopted in this work should be applicable to various other processes for producing fuels and chemicals, such as biodiesel, bioplastics, and enzymes, from biological materials that are renewable. The systems for downstream processing involved in these processes often resemble each other.

In today's highly competitive environment, the retrofitting of an existing process plant can be far more viable economically than constructing a new one. The profound efficiency of the methodology adopted renders it possible to generate with dispatch a set of optimal or near-optimal flowsheets by systematically replacing one or more existing operating units with newly identified operating units that can possibly be more advantageous economically than the existing ones. Naturally, this would facilitate choice between retrofitting and new construction.

The results obtained in this work have given rise to a novel paradigm for process development and design through process synthesis. This novel paradigm appears to follow the basic tenet of concurrent engineering. It makes rapid prototyping of flowsheets possible in process design. The cost is taken into account at the early conceptual design stage. Moreover, other considerations, e.g., sustainability, can be integrated in this paradigm to satisfy the ever-shifting environmental, societal, and regulatory constraints at the early stage of design, thereby circumventing serious cost overrun in process development and design.

Acknowledgment

This is contribution No. 04-235-J, Department of Chemical Engineering, Kansas Agricultural Experiment Station, Kansas State University, Manhattan, KS 66506, U.S.A, from which the first three authors received financial support.

Supporting Information Available: Additional discussion, computational details and results, and cost estimation procedures. This material is available free of charge via the Internet at <http://pubs.acs.org>.

References and Notes

- (1) Douglas, J. M. *Conceptual Design of Chemical Processes*; McGraw-Hill: New York, 1988.
- (2) Sirola, J. Industrial Applications of Chemical Process Synthesis. In *Advances in Chemical Engineering*; Academic Press: San Diego, CA, 1996, Vol. 23, pp 1–62.
- (3) Biegler, L. T.; Grossmann, I. E.; Westerberg, A. W. *Systematic Methods of Chemical Process Design*; Prentice Hall: Upper Saddle River, NJ, 1997; pp 497–498.
- (4) El-Halwagi, M. M.; Manousiouthakis, V. Synthesis of Mass Exchange Networks. *AIChE J.* **1989**, *35*, 1233–1244.
- (5) El-Halwagi, M. M. *Pollution Prevention through Process Integration: Systematic Design Tools*; Academic Press: New York, 1997.
- (6) El-Halwagi, M. M.; Spriggs, H. G. Solve Design Puzzles with Mass Integration. *Chem. Eng. Prog.* **1998**, *94* (8), 25–44.
- (7) Keller, G. E.; Bryan, P. F. Process Engineering Moving in New Directions. *Chem. Eng. Prog.* **2000**, *96* (1), 41–50.
- (8) Lightfoot, E. N. Unpredictability and Evolution of Novel Designs. Presented at the 15th International Congress of Chemical and Process Engineering, Praha, Czech Republic, 25–29 August, 2002.
- (9) Ladisch, M. R. Fermentation-derived butanol and scenarios for its uses in energy-related applications. *Enzyme Microb. Technol.* **1991**, *13*, 280–283.
- (10) Perry, R. H.; Green, D. W.; Maloney, J. O. *Perry's Chemical Engineers' Handbook*; McGraw-Hill: New York, NY, 1997; Tables 3-1, 3-2, and 13-19.

- (11) Compere, A. L.; Griffith, W. L. Evaluation of Substrates for Butanol Production. *Dev. Ind. Microbiol.* **1979**, *20*, 509–517.
- (12) NRC (National Research Council) *Field Testing Genetically Modified Organisms*; National Academy Press: Washington, DC, 1989.
- (13) Geng, Q. H.; Park, C. H. Pervaporative Butanol Fermentation by *Clostridium acetobutylicum* B18. *Biotechnol. Bioeng.* **1994**, *43*, 978–986.
- (14) Qureshi, N.; Maddox, I. S.; Friedl, Anton, Application of Continuous Substrate Feeding to the ABE Fermentation. Relief of Product Inhibition using Extraction, Perstraction, Stripping, and Pervaporation. *Biotechnol. Prog.* **1992**, *8*, 382–390.
- (15) NRC (National Research Council) *Biobased Industrial Products: Priorities for Research and Commercialization*; National Academy Press: Washington, DC, 1999.
- (16) Cooney, C. L.; Humphrey, A. E. *The Principles of Biotechnology: Engineering Considerations*; Pergamon Press: New York, 1989.
- (17) Friedl, A.; Windsperger, A. M.; Minkov, S. Inertgasstrippen als Produktabtrennung bei der Aceton-Butanol-Gaerung und der Ethanol-Gaerung. *Zuckerindustrie* **1989**, *114*, 216–221.
- (18) Ladisch, M. R. *Bioseparations Engineering: Principles, Practice, and Economics*; Wiley-Interscience: New York, 2001.
- (19) Dadgar, A. M.; Foutch, G. L. Improving the Acetone-Butanol Fermentation Process with Liquid-Liquid Extraction. *Biotechnol. Prog.* **1988**, *4*, 36–39.
- (20) Park, C. H.; Geng, Q. H. Simultaneous Fermentation and Separation in the Ethanol and ABE Fermentation. *Sep. Purif. Methods* **1992**, *21*, 135–138.
- (21) Qureshi, N.; Blaschek, H. P. Recovery of Butanol from Fermentation Broth by Gas Stripping. *Renewable Energy* **2001**, *22*, 557–564.
- (22) Ross, B. A.; Seider, W. D. Simulation of Three-Phase Distillation Towers. *Comput. Chem. Eng.* **1980**, *5*, 7–20.
- (23) Schuil, J. A.; Bool, K. K. Three-Phase Flash and Distillation. *Comput. Chem. Eng.* **1985**, *9*, 295–300.
- (24) Marlatt, J. A.; Datta, R. Acetone-Butanol Fermentation Process Development and Economic Evaluation. *Biotechnol. Prog.* **1986**, *2*, 23–28.
- (25) Pucci, A.; Mikitenko, P.; Asselineau, L. Three-Phase Distillation. Simulation and Application to the Separation of Fermentation Products. *Chem. Eng. Sci.* **1986**, *41*, 485–494.
- (26) Hickey, P. J.; Slater, C. S. The Selective Recovery of Alcohols from Fermentation Broths by Pervaporation. *Sep. Purif. Methods* **1990**, *19*, 93–115.
- (27) Belter, P. A.; Cussler, E. L.; Hu, W. S. *Bioseparations: Downstream Processing for Biotechnology*; John Wiley & Sons: New York, 1988.
- (28) Harrison, R. G.; Todd, P.; Rudge, S. R.; Petrides, D. P. *Bioseparations Science and Engineering*; Oxford University Press: New York, 2003.
- (29) Feng, G.; Fan, L. T.; Friedler, F. Synthesizing Alternative Sequences via a P-graph-based Approach in Azeotropic Distillation Systems. *Waste Manage.* **2000**, *20*, 639–643.
- (30) Feng, G.; Fan, L. T.; Friedler, F.; Seib, P. A. Identifying Operating Units for the Design and Synthesis of Azeotropic-Distillation Systems. *Ind. Eng. Chem. Res.* **2000**, *39*, 175–184.
- (31) Bertok, B.; Friedler, F.; Feng, G.; Fan, L. T. Systematic Generation of the Optimal and Alternative Flowsheets for Azeotropic Distillation Systems. *Comput. Aided Chem. Eng.* **2001**, *9*, S351–S356.
- (32) Doherty, M. F.; Malone, M. F. *Conceptual Design of Distillation Systems*; McGraw-Hill: New York, 2001.
- (33) Diwekar, U. M.; Frey, H. C.; Rubin, E. S. Synthesizing Optimal Flowsheets: Applications to IGCC System Environmental Controls. *Ind. Eng. Chem. Res.* **1992**, *31*, 1927–1935.
- (34) Friedler, F.; Tarjan, K.; Huang, Y. W.; Fan, L. T. Combinatorial Algorithms for Process Synthesis. *Comput. Chem. Eng.* **1992**, *16*, S313–S320.
- (35) Friedler, F.; Tarjan, K.; Huang, Y. W.; Fan, L. T. Graph-Theoretic Approach to Process Synthesis: Axioms and Theorems. *Chem. Eng. Sci.* **1992**, *47*, 1973–1988.
- (36) Friedler, F.; Tarjan, K.; Huang, Y. W.; Fan, L. T. Graph-Theoretic Approach to Process Synthesis: Polynomial Algorithm for Maximal Structure Generation. *Comput. Chem. Eng.* **1993**, *17*, 929–942.
- (37) Friedler, F.; Fan, L. T. Combinatorial Acceleration of the Branch and Bound Search for Process Network Synthesis. Symposium on Applied Mathematical Programming and Modeling, Budapest, Hungary, January 6–8, 1993.
- (38) Friedler, F.; Varga, J. B.; Fan, L. T. Decision Mapping: A Tool for Consistent and Complete Decisions in Process Synthesis. *Chem. Eng. Sci.* **1995**, *50*, 1755–1768.
- (39) Friedler, F.; Varga, J. B.; Fan, L. T. *Algorithmic Approach to the Integration of Total Flowsheet Synthesis and Waste Minimization*; AIChE Symposium Series 303; El-Halwagi, M. M., Petrides, D. P., Eds.; American Institute of Chemical Engineers: New York, 1995; pp 86–97.
- (40) Friedler, F.; Varga, J. B.; Feher, E.; Fan, L. T. *Combinatorially Accelerated Branch-and-Bound Method for Solving the MIP Model of Process Network Synthesis, Nonconvex Optimization and Its Applications, State of the Art in Global Optimization, Computational Methods and Applications*; Floudas, C. A., Pardalos, P. M., Eds.; Kluwer Academic Publishers: Dordrecht, The Netherlands, 1996; pp 609–626.
- (41) Imreh, B.; Friedler, F.; Fan, L. T. *An Algorithm for Improving the Bounding Procedure in Solving Process Network Synthesis by a Branch-and-Bound Method, Nonconvex Optimization and Its Applications, Developments in Global Optimization*; Kluwer Academic Publishers: Dordrecht, The Netherlands, 1997; pp 315–348.
- (42) Friedler, F.; Fan, L. T.; Imreh, B. Process Network Synthesis: Problem Definition. *Networks* **1998**, *28*, 119–124.
- (43) Brendel, M. H.; Friedler, F.; Fan, L. T. Combinatorial Foundation for Logical Formulation in Process Network Synthesis. *Comput. Chem. Eng.* **2000**, *24*, 1859–1864.
- (44) Peters, M. S.; Timmerhaus, K. D.; West, R. E. *Plant Design and Economics for Chemical Engineers*; McGraw-Hill, New York, 2003; pp 158–188.
- (45) Halim, I.; Srinivasan, R. Systematic waste minimization in chemical processes. I. Methodology. *Ind. Eng. Chem. Res.* **2002**, *41*, 196–207.
- (46) Hertwig, T. A.; Xu, A.; Nagy, A.; Pike, R. W.; Hopper, J. R.; Yaws, C. L. A Prototype System for Economic, Environmental and Sustainable Optimization of a Chemical Complex. *Clean Technol. Environ. Policy* **2002**, *3*, 363–370.
- (47) Lee, S.; Park, S. Synthesis of Mass Exchange Network Using Process Graph Theory. *Comput. Chem. Eng.* **1996**, *20*, S201–S205.
- (48) Leitold, A.; Hangos, K. M.; Tuza, Z. Structure Simplification of Dynamic Process Models. *J. Process Control* **2002**, *12*, 69–83.
- (49) Partin, L. R. Combinatorial Analysis Application for Flowsheet Synthesis of Chemical Plants. *MapleTech.* **1998**, *5*, 15–26.
- (50) Aspen Plus 11.1, 2003.
- (51) Rudd, D. F.; Powers, G. J.; Sirola, J. J. *Process Synthesis*; Prentice-Hall: Englewood Cliffs, NJ, 1973.
- (52) Seader, J. D.; Henley, E. J. *Separation Process Principles*; John Wiley & Sons: New York, 1998.
- (53) King, C. J. *Separation Processes*; McGraw-Hill: New York, 1980.

Accepted for publication July 26, 2004.

BP049845V